

# Silo Cut Sheet

## External Vent/Overflow & CIP Lines

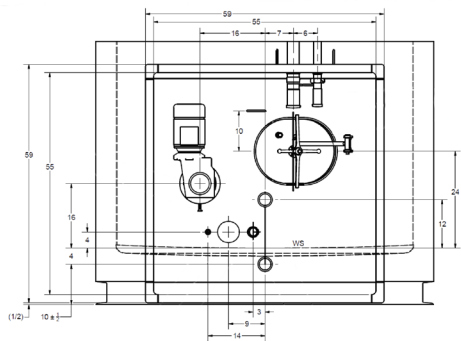
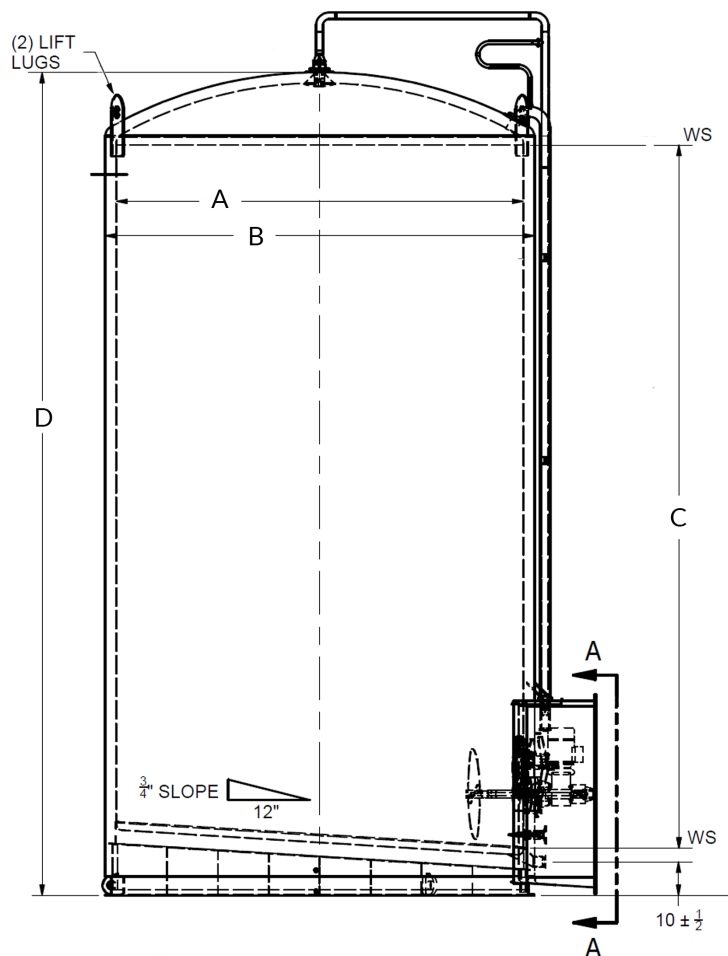

### Additional notes:

- Product Contact: 304L Stainless w/ 32 RA Finish
- Exterior: Carbon Steel w/ White Urethane Paint
- Alcove: 55" x 55" x 18" (12" wall thickness)
- 3" Fiberglass Insulation on Top Head
- 3" EPS Insulation on Sidewall
- 4" Foamglass Insulation on Bottom Head
- CIPA-H (Clean-in Place Agitator)
- Lines designed for 400 GPM
- Built to 3A standards

### Nozzle Schedule Includes:

- 3" Inlet
- 3" Outlet
- Horizontal Agitator
- Manway 16" x 20" w/ Sample
- Level Gauge Sleeve
- Thermowell w/ 5" dial thermometer
- Recording Thermowell
- 3" Vent/Overflow Line
- 2" CIP Line w/ CIP Device

### Optional Items:

- Product Contact Available in 316L or Duplex
- Exterior available in 304L or 201 stainless
- Alcove available in various sizes
- Insulations available for higher temperatures
- Insulation and heat tapes available for lines
- Vertical agitation for a variety of products
- Heat Transfer Surface, Dimple Jacket, or Laser
- Other line sizes available for higher GPM rates
- Ask DCI, Inc. Sales for other options available

U.S. GALLONS	A (ID)	B (OD)	C (S.S.)	D (OAH)	WEIGHT LBS
4,000	84	90.75	14' 4"	16' 11"	6,000
5,000	95.75	102.75	13' 8"	16' 5"	7,800
5,000	107	113.75	11' 0"	13' 11"	7,800
6,000	95.75	102.75	16' 6"	19' 3"	8,700
6,000	107	113.75	13' 2"	16' 1"	8,700
6,000	120	126.75	10' 6"	13' 7"	8,700
7,000	95.75	102.75	19' 0"	21' 9"	9,400
7,000	107	113.75	15' 4"	18' 3"	9,400
7,000	120	126.75	12' 4"	15' 5"	9,400
8,000	95.75	102.75	21' 8"	24' 5"	10,100
8,000	107	113.75	17' 4"	20' 3"	10,100
8,000	120	126.75	14' 0"	17' 1"	10,100
10,000	95.75	102.75	27' 0"	29' 9"	11,700
10,000	107	113.75	21' 8"	24' 7"	11,700
10,000	120	126.75	17' 4"	20' 5"	11,700
10,000	132	138.75	14' 8"	17' 11"	11,700
10,000	144	150.75	12' 4"	15' 9"	11,700
12,000	107	113.75	26' 0"	28' 11"	13,000
12,000	120	126.75	20' 10"	23' 11"	13,000
12,000	132	138.75	17' 2"	20' 5"	13,000
15,000	95.75	102.75	40' 6"	43' 3"	14,900
15,000	107	113.75	32' 6"	35' 5"	14,900
15,000	120	126.75	26' 0"	29' 1"	14,900
15,000	132	138.75	21' 6"	24' 9"	14,900
15,000	137.5	144.25	20' 0"	23' 4"	14,900
15,000	144	150.75	18' 2"	21' 7"	14,900
20,000	120	126.75	34' 8"	37' 9"	18,000
20,000	132	138.75	28' 6"	31' 9"	18,000
20,000	137.5	144.25	26' 4"	29' 8"	18,000
20,000	144	150.75	24' 0"	27' 5"	18,000
25,000	132	138.75	35' 6"	38' 9"	21,000
25,000	137.5	144.25	32' 10"	36' 2"	21,000
25,000	144	150.75	30' 0"	33' 5"	21,000
30,000	132	138.75	42' 6"	45' 9"	24,000
30,000	137.5	144.25	39' 4"	42' 8"	24,000
30,000	144	150.75	36' 0"	39' 5"	24,000
40,000	132	138.75	56' 8"	59' 11"	30,000
40,000	137.5	144.25	52' 4"	55' 8"	30,000
40,000	144	150.75	47' 8"	51' 1"	30,000
50,000	137.5	144.25	65' 2"	68' 6"	36,000
50,000	144	150.75	59' 6"	62' 11"	36,000
60,000	144	150.75	71' 4"	74' 9"	42,000
70,000	156	162.75	71' 0"	74' 7"	53,000



DCI, Inc.  
600 North 54th Ave  
St. Cloud, MN 56303  
Phone: 320-252-8200  
www.dciinc.com

Stay up to date with everything DCI, Inc.!

